

WARNING: Remove Power prior to replacing blown fuses

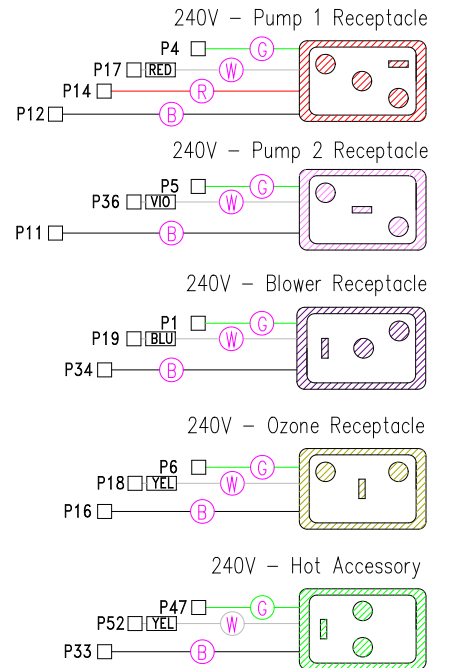
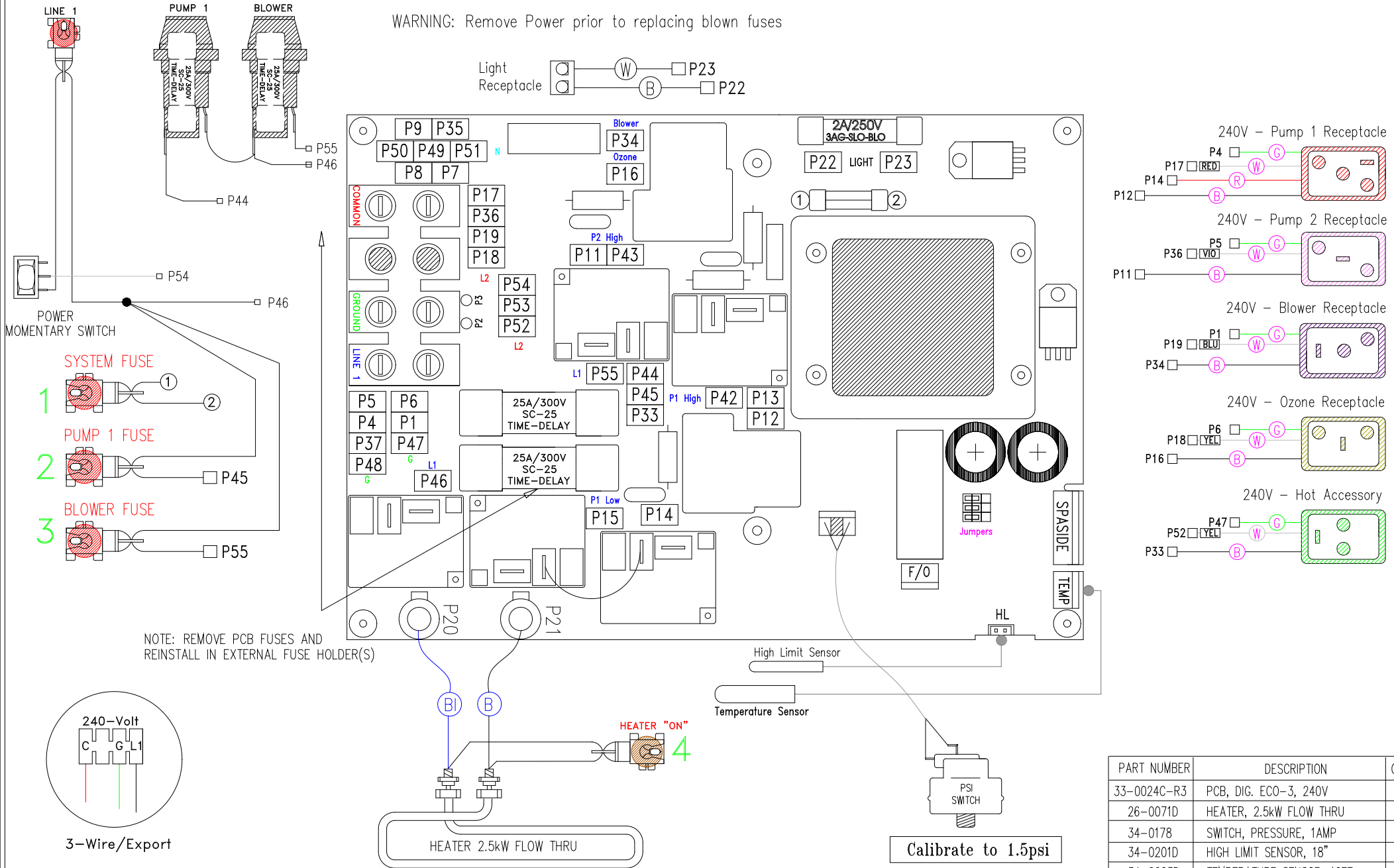

PART NUMBER	DESCRIPTION	QTY
33-0024C-R3	PCB, DIG. ECO-3, 240V	1
26-0071D	HEATER, 2.5kW FLOW THRU	1
34-0178	SWITCH, PRESSURE, 1AMP	1
34-0201D	HIGH LIMIT SENSOR, 18"	1
34-0203D	TEMPERATURE SENSOR, 10FT	1

Manufacture Notes:

System replacement fuse included with each unit (attached to inside faceplate).

Dwg. No.
M55A0-DUQY-Z5

Drawn
GC
Date
02.13.07
Diagram No.
8027

Rev
1

Wire Color Code

B - Black	G - Green
Br - Brown	Bl - Blue
R - Red	V - Violet
O - Orange	W - White
Y - Yellow	Gr - Gray

Calibrate to 1.5psi

WARNING: Remove Power prior to replacing blown fuses

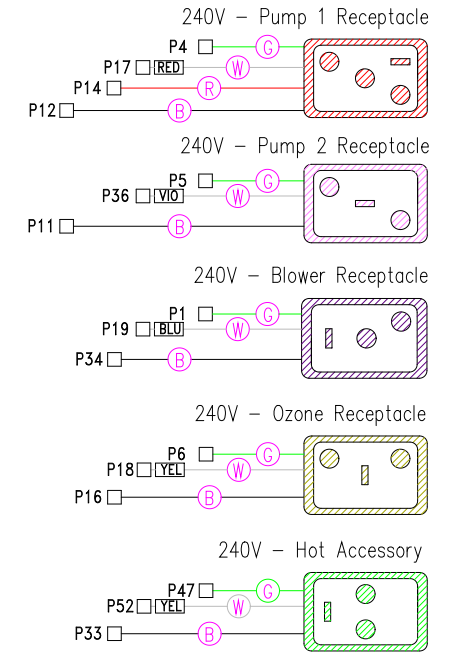
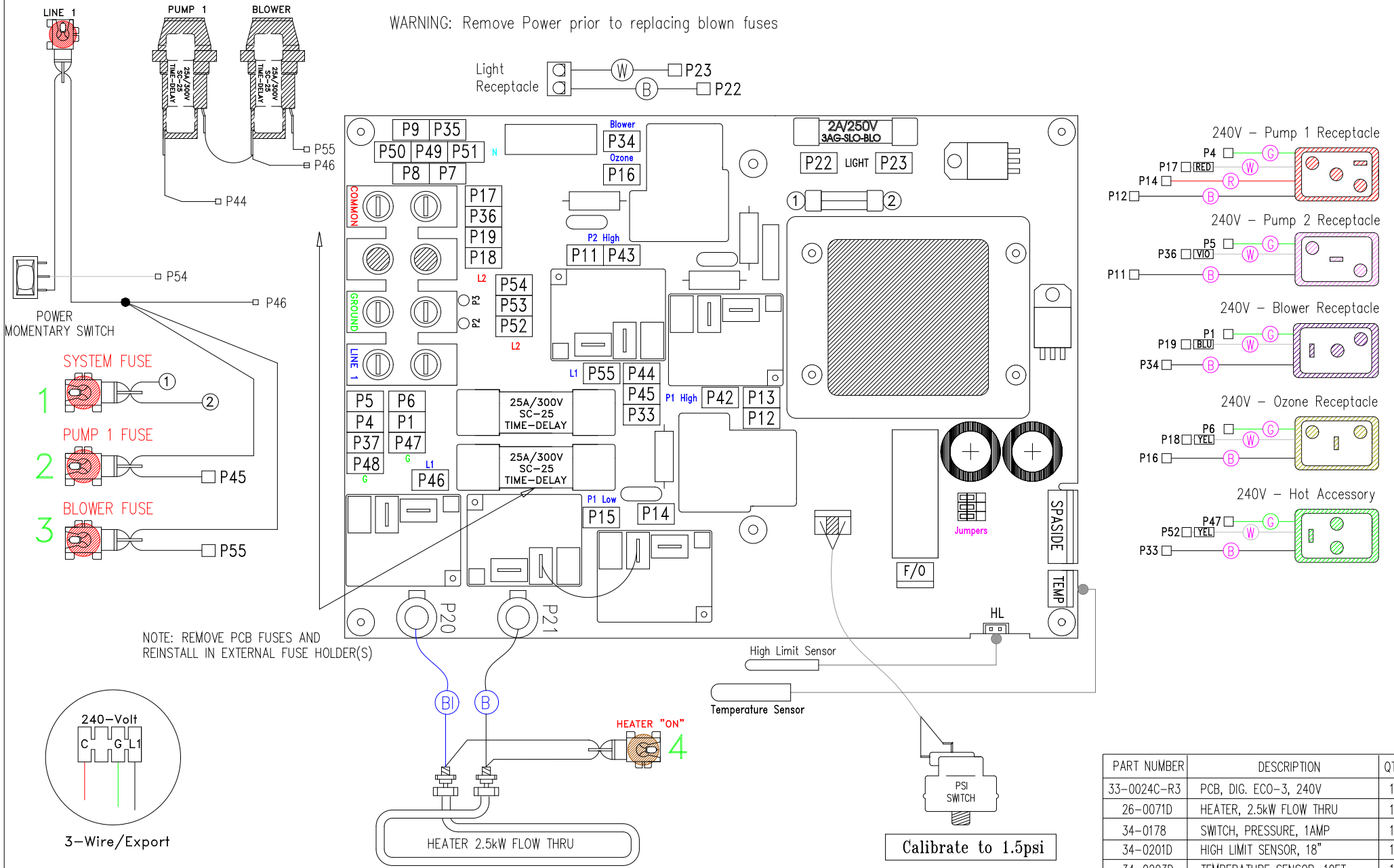

NOTE: REMOVE PCB FUSES AND REINSTALL IN EXTERNAL FUSE HOLDER(S)

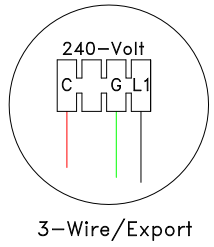

PART NUMBER	DESCRIPTION	QTY
33-0024C-R3	PCB, DIG. ECO-3, 240V	1
26-0071D	HEATER, 2.5kW FLOW THRU	1
34-0178	SWITCH, PRESSURE, 1AMP	1
34-0201D	HIGH LIMIT SENSOR, 18"	1
34-0203D	TEMPERATURE SENSOR, 10FT	1

Manufacture Notes:

System replacement fuse included with each unit (attached to inside faceplate).

Dwg. No. M55A0-DUQY-Z5

Drawn GC
Rev 1
Date 02.13.07
Diagram No. 8027

Wire Color Code	
B - Black	G - Green
Br - Brown	Bl - Blue
R - Red	V - Violet
O - Orange	W - White
Y - Yellow	Gr - Gray