

LIGHT RECEPT.  
"WHITE 2-PIN" AMP

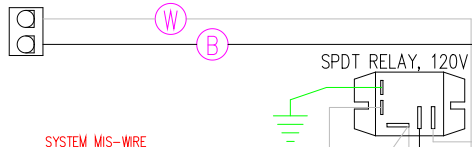

SYSTEM MIS-WIRE

HIGH-LIMIT TRIPPED

HIGH-LIMIT

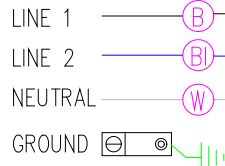
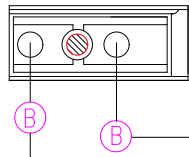

PART NUMBER	DESCRIPTION	QTY
26-0071	HEATER, 5.5kW FLOW THRU	1
34-0002	SWITCH, AIR - SPDT	3
34-0012	HIGH LIMIT, 5/16" BULB	1
34-0020	SWITCH, ROCKER - SPDT	1
34-0030	THERMOSTAT, 5/16" BULB - 24" CAP	1
34-0033	TIMER, 24HR, 120V/60Hz - STD	1
34-0059	SWITCH, AIR - DPDT	1
34-0178	SWITCH, PRESSURE - 1AMP	1
35-0002	RELAY, SPDT, 15A, 120V, T-91	2
35-0012	CONTACTOR, DPST, 30/40A, 120V	1
35-0014	CONTACTOR, DPST, 50A, 120V	1
35-0025	CONTACTOR, SPST, 30A, 120V	1
37-0002	TRANSFORMER, LIGHT, 12VA-120V, 1AMP	1

#1 - Universal System, connecting the White/Component receptacle wire to the corresponding position on the Universal Terminal Block determines component voltage.  
#2 - Low Current (heater off w/high-speed pump or blower) or High Current (no heater restriction)

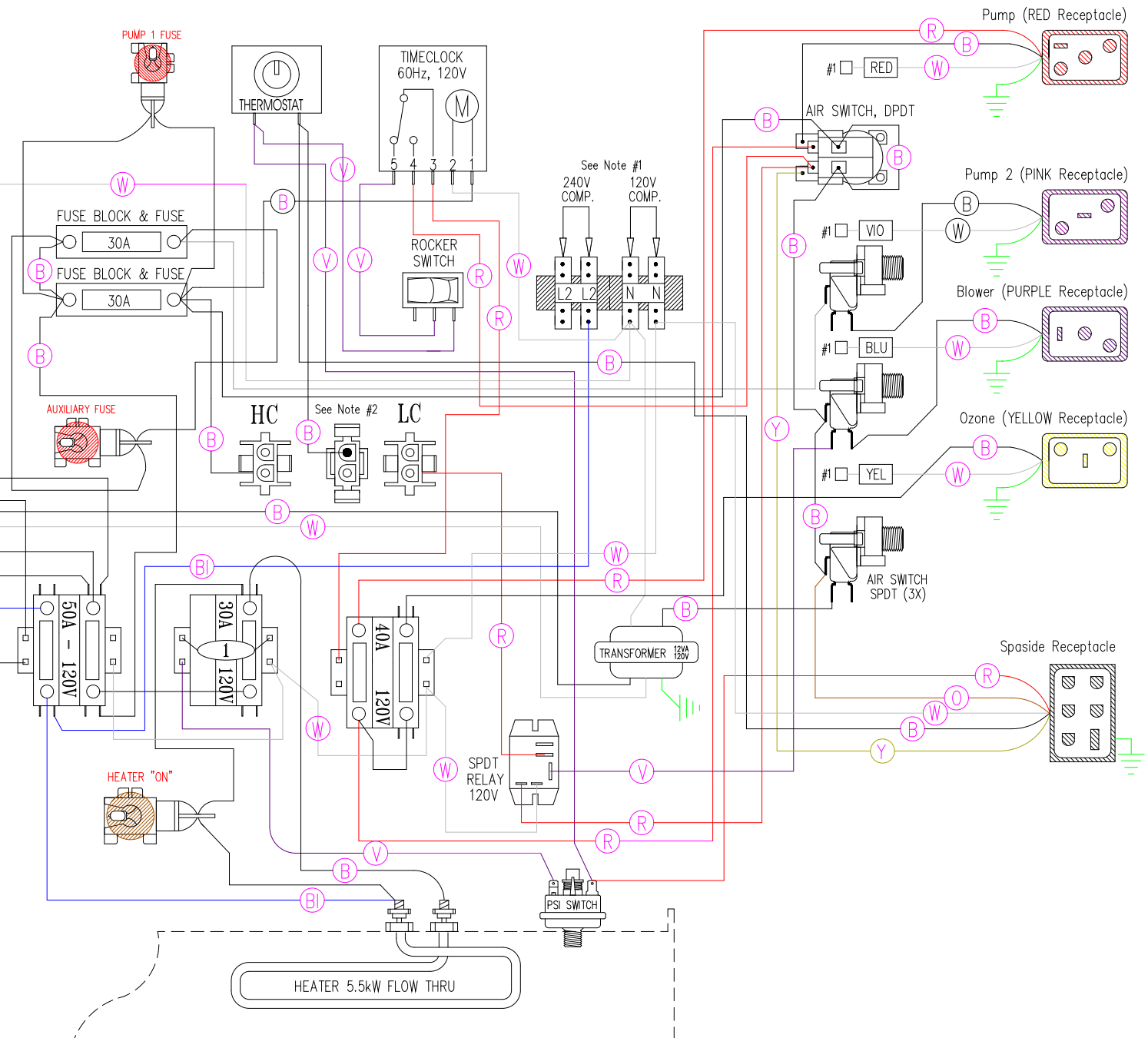

Dwg. No.	506G0-DKS5	Drawn	GC	Rev	3	Wire Color Code B - Black    G - Green Br - Brown   BI - Blue R - Red     V - Violet O - Orange   W - White Y - Yellow   Gr - Gray
Date		02.01.07				
Diagram No.		7026				