

TO CONVERT CIRCUIT 120V OR 240V MOVE WHITE WIRE ACCORDINGLY
120V COMPONENT = OPEN POSITION AT CONNECTION BLOCK #4
240V COMPONENT = OPEN POSITION AT CONNECTION BLOCK #2

26-0063-M7 - Gas Housing

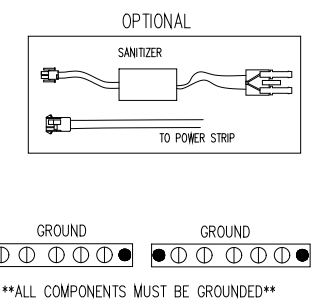
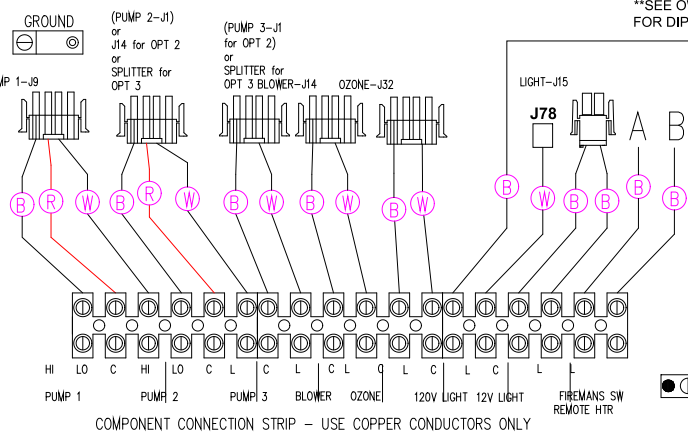
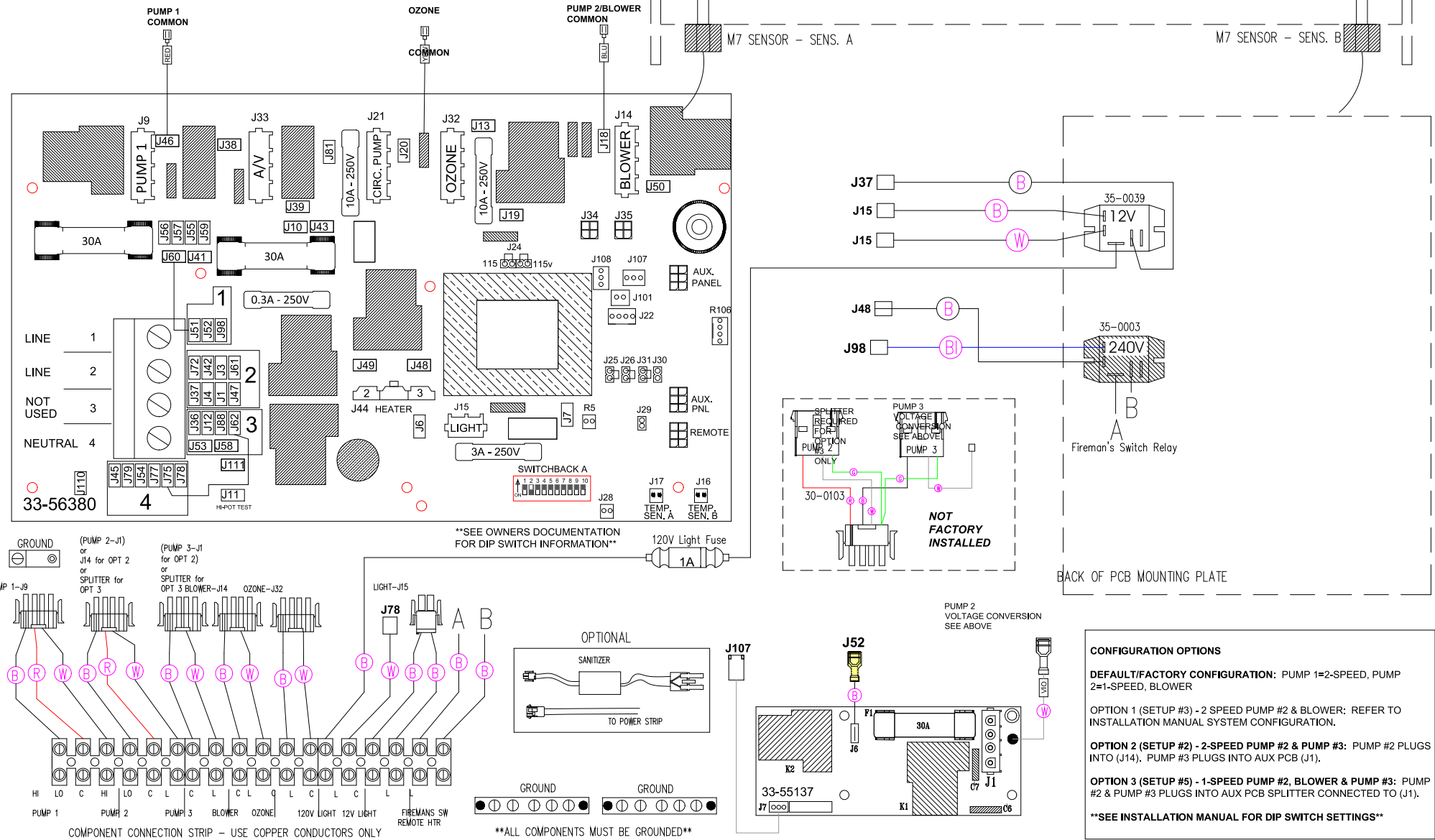

CONFIGURATION OPTIONS

DEFAULT/FACTORY CONFIGURATION: PUMP 1=2-SPEED, PUMP 2=1-SPEED, BLOWER

OPTION 1 (SETUP #3) - 2-SPEED PUMP #2 & BLOWER: REFER TO INSTALLATION MANUAL SYSTEM CONFIGURATION.

OPTION 2 (SETUP #2) - 2-SPEED PUMP #2 & PUMP #3: PUMP #2 PLUGS INTO (J14). PUMP #3 PLUGS INTO AUX PCB (J1).

OPTION 3 (SETUP #5) - 1-SPEED PUMP #2, BLOWER & PUMP #3: PUMP #2 & PUMP #3 PLUGS INTO AUX PCB SPLITTER CONNECTED TO (J1).

****SEE INSTALLATION MANUAL FOR DIP SWITCH SETTINGS****

HYDRO-QUIP
CORONA, CA (951) 273-7575

Manufacture Notes:

Dwg. No. **G822A0-KLPQY-J**

Drawn MO
Date 10.05.17
Rev 01
Diagram No. **5197**

Wire Color Code

B - Black	G - Green
Br - Brown	Bl - Blue
R - Red	V - Violet
O - Orange	W - White
Y - Yellow	Gr - Gray

DEFAULT SYSTEM SETUP: #18 - REFER TO INSTALLATION MANUAL