

TO CONVERT CIRCUIT 120V OR 240V MOVE WHITE WIRE ACCORDINGLY
 120V COMPONENT = WHT AC/NEUTRAL
 240V COMPONENT = RED AC/LINE 2

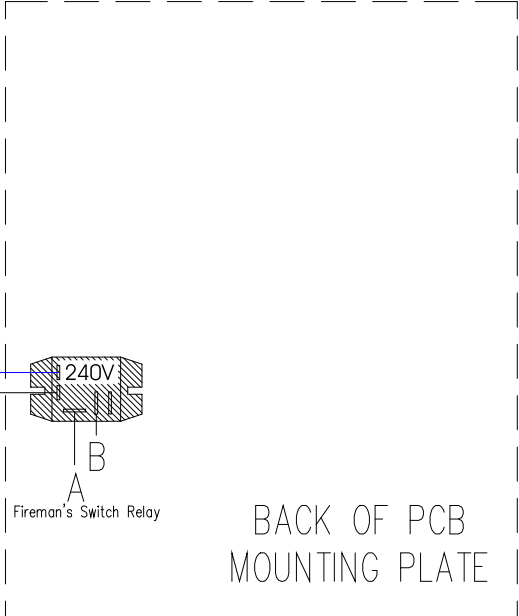
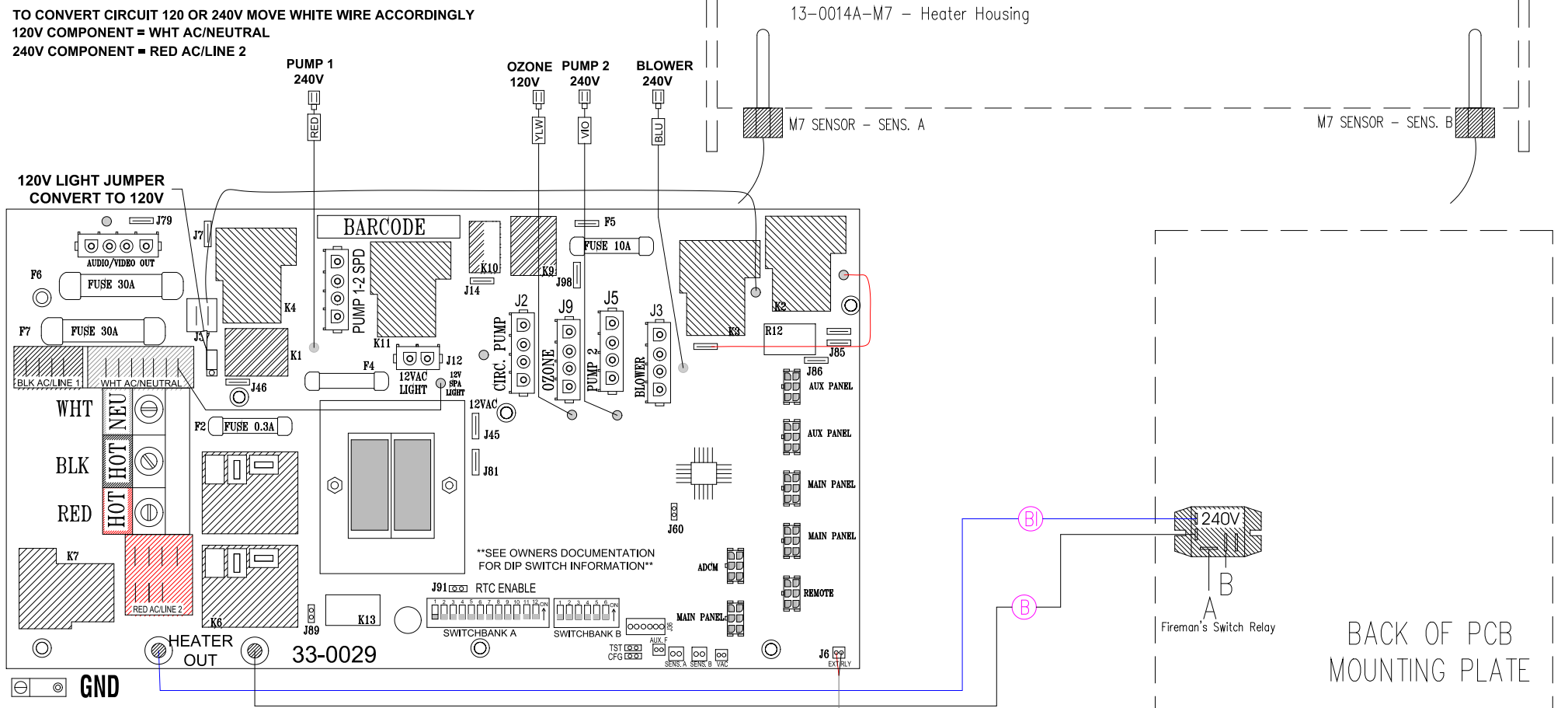

CONFIGURATION OPTIONS

DEFAULT/FACORY CONFIGURATION: PUMP 1=2-SPEED, PUMP 2=1-SPEED, BLOWER

OPTION 1 - 2 SPEED PUMP #2 & BLOWER: PUMP #2 LOW SPEED PLUGS INTO J3. BLOWER THEN PLUGS INTO AUX PCB.

OPTION 2 - 2-SPEED PUMP #2 & PUMP #3: PUMP #2 LOW SPEED PLUGS INTO J3. PUMP #3 PLUGS INTO AUX PCB.

OPTION 3 - 1-SPEED PUMP #2, BLOWER & PUMP #3: PUMP #3 PLUGS INTO AUX PCB.

****SEE INSTALLATION MANUAL FOR DIP SWITCH SETTINGS****

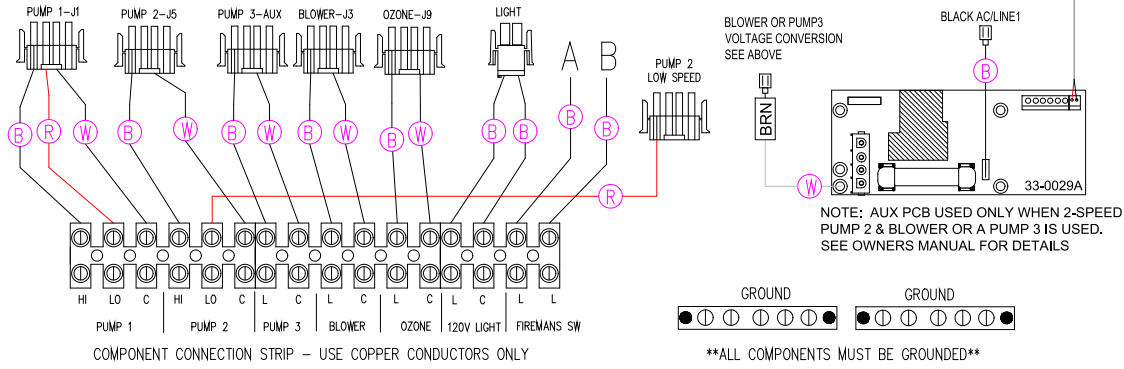

HYDRO-QUIP
 CORONA, CA (951) 273-7575

Manufacture Notes:

Dwg. No. G822A0-KLPQY-J	Drawn MBS	Rev 03	Wire Color Code
Date 12.15.11	Diagram No. 5171		B - Black Br - Brown R - Red O - Orange Y - Yellow G - Green BI - Blue V - Violet W - White Gr - Gray

DIP SWITCHES & PERSISTANT MEMORY: TO MAKE CHANGES TO THE CONFIGURATION DIP SWITCHES PERSISTANT MEMORY MUST BE RESET. 1) POWER SYSTEM OFF, 2)TURN SWITCH A12 "ON" AND MAKE DESIRED CHANGES TO THE DIP-SWITCH(S), 3) POWER SYSTEM BACK ON, LET THE SYSTEM BOOT UP COMPLETELY, CHECK THAT DESIRED CHANGES WERE MADE, 4) POWER SYSTEM OFF AND TURN SWITCH A12 "OFF" (IF USING A NON-CONDUCTIVE TOOL THE SWITCH MAY BE TURNED OFF WHILE THE POWER IS ON)