

# HYDROQUIP™

## ULTIMATE SERIES SOLID-STATE

### SYSTEM OPERATION MANUAL

THE **SMART CHOICE**™

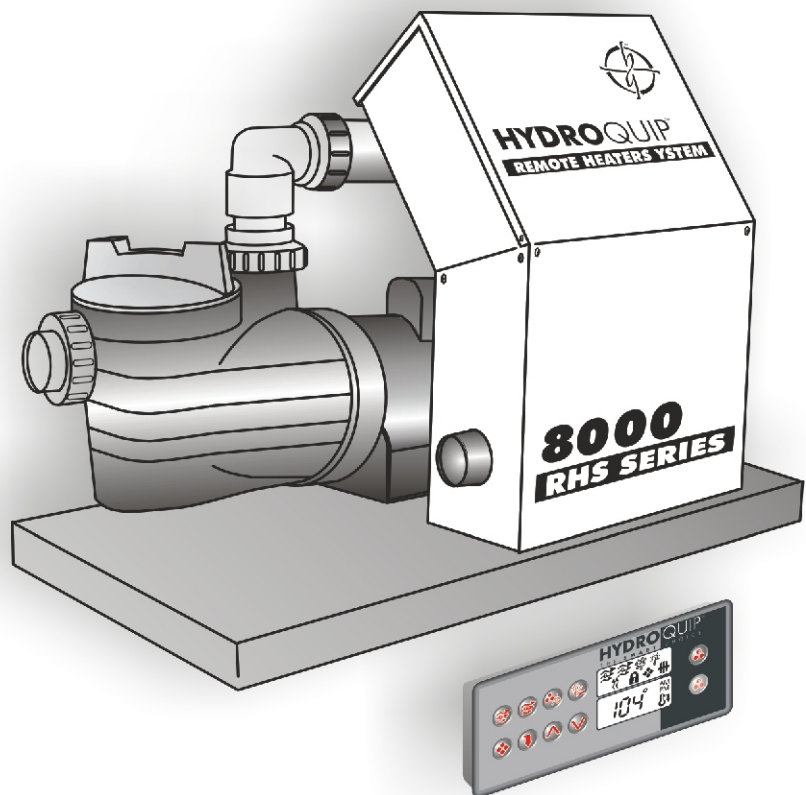

**8600**

# CONTENTS

<b>Important Safety Instructions</b> .....	<b>2</b>
<b>INTRODUCTION</b>	
<b>Major Component Illustration</b> .....	<b>4</b>
<b>SYSTEM OPERATION</b>	
<b>Heater Operation</b> .....	<b>5</b>
<b>Spaside Control</b> .....	<b>6</b>
<b>Spa Light</b> .....	<b>11</b>
<b>Error Identification</b> .....	<b>11</b>
<b>OPERATIONAL CONSIDERATIONS</b>	
<b>Warm Weather Conditions</b> .....	<b>12</b>
<b>Filtration</b> .....	<b>12</b>
<b>Freeze Protection &amp; Winterizing</b> .....	<b>13</b>
<b>Chemical Water Treatment</b> .....	<b>13</b>
<b>TROUBLESHOOTING</b> .....	<b>14</b>
	<b>14</b>
<b>Warranty Information</b> .....	<b>18</b>

# IMPORTANT SAFETY INSTRUCTIONS

## READ AND FOLLOW ALL INSTRUCTIONS

! **DANGER** To reduce the risk of injury, do not permit children to use this product unless they are closely supervised at all times.

! **WARNING - RISK OF CHILD DROWNING.** Extreme caution must be exercised to prevent unauthorized access by children. To avoid accidents, ensure that children cannot use a spa or hot tub unless they are supervised at all times.

! **DANGER** To reduce the risk of injury to persons, do not remove suction fittings.

► Spa location must accommodate sufficient drainage of water around the base of the structure, as well as the power source compartment.

► Prolonged immersion in water that is warmer than normal body temperature can result in a dangerous condition known as HYPERTHERMIA. The causes, symptoms, and effects of hyperthermia may be described as follows: Hyperthermia occurs when the internal temperature of the body reaches a level several degrees above the normal body temperature of 98.6°F. The symptoms of hyperthermia include dizziness, fainting, drowsiness, lethargy, and an increase in the internal temperature of the body. The effects of hyperthermia include (1) unawareness of impending hazard, (2) failure to perceive heat, (3) failure to recognize the need to exit spa, (4) physical inability to exit spa, (5) fetal damage in pregnant women, (6) unconsciousness resulting in danger of drowning. **WARNING** The use of alcohol, drugs or medication can greatly increase the risk of fatal hyperthermia in hot tubs and spas.

! **DANGER - RISK OF ELECTRICAL SHOCK.** Install at least 5 feet (1.5m) from all metal surfaces. (A spa may be installed within 5 feet of metal surfaces if each metal surface is permanently connected by a solid copper conductor attached to the wire connector on the terminal box that is provided for this purpose. Refer to NEC and local codes in effect at the time of installation.)

► A pressure wire connector is provided on the control box to permit connection of a solid copper bonding conductor between this point and any equipment, metal enclosures of electrical equipment, metal water pipe, or conduit within 5 feet (1.5m) of the unit as needed to comply with local requirements.

► Bond accessible metal to the dedicated connector on the equipment grounding bus, bond the equipment ground bus to the local common bonding grid as part of the installation in the form of (1) a reinforced concrete slab for support, (2) a ground plate provided beneath the hot tub or spa, or (3) a permanent ground connection that is acceptable to the local inspection authority.

! **DANGER RISK OF ELECTRICAL SHOCK.** Do not permit any electrical appliance, such as a light, telephone, radio, or television, within 5 feet (1.5m) of a spa or hot tub.

### To reduce the risk of injury:

► The water in a spa or hot tub should never exceed 104°F (40°C). Water temperatures between 100°F (38°C) and 104°F (40°C) are considered safe for a healthy adult. Lower water temperatures are recommended for extended use (exceeding 10-15 minutes) and for young children.

► Excessive water temperatures have a high potential for causing fetal damage during the early months of pregnancy, pregnant or possibly pregnant women should limit spa or hot tub water temperatures to 100°F(38°C).

Before entering the spa or hot tub, the user should measure the water temperature with an accurate thermometer.

The use of alcohol, drugs, or medication before or during spa or hot tub use may lead to unconsciousness with the possibility of drowning.

Persons suffering from obesity or with a medical history of heart disease, low or high blood pressure, circulatory system problems, or diabetes should consult a physician before using a spa or hot tub.

Persons using medication should consult a physician before using a spa or hot tub since some medication may affect heart rate, blood pressure, and circulation.

#### **For Units with a GFCI (Ground Fault Circuit Interrupter)**

This appliance is provided with a ground-fault-circuit-interrupter located on the control box. Before each use and with the unit operating, push the test button. The unit should stop operating and the reset button should appear. Push the reset button. The unit should now operate normally. If the interrupter does not perform in this manner, a ground current is flowing indicating the possibility of electrical shock. Disconnect the power, or unplug from receptacle, until the fault has been identified and corrected.

#### **For Cord and Plug Connected Units**

Connected to a grounded, grounding type receptacle only. NEVER connect the spa to an extension cord.

Do not bury the cord.

**WARNING** To reduce the risk of electrical shock, replace damaged cord immediately.

#### **For Permanently Installed Units**

A terminal marked "G" or "ground" is provided in the wiring box located inside the equipment compartment. To reduce the risk of electric shock, connect the terminal or connector to the grounding terminal of your electrical service or supply panel with a continuous green insulated copper wire in accordance with National Electric Code Table 250-95 and any other local codes in effect at the time of the installation.

#### **For Permanently Installed Units not Provided with an Internal Disconnecting Method**

The electrical supply for this product must include a suitably rated switch or circuit breaker to open all ungrounded supply conductors to comply with Section 422-30 of the National Electric Code, ANSI/NFPA 70 1987. The disconnecting means must be readily accessible to the tub occupant but installed at least 5 feet (1.5m) from the tub water.

#### **For Units with Gas Heaters**

**WARNING** - Do not install indoors. This unit uses a gas heater that requires proper ventilation and is intended for outdoor use only.

#### **For UL Listed Equipment Assemblies**

Install at least 5 feet (1.5m) from tub water using nonmetallic plumbing. Install blower no less than 1 foot (305mm) above the maximum water level to prevent water from contacting electrical equipment. Install in accordance with the installation instructions. To reduce the risk of drowning from hair and body entrapment, install a suction fitting(s) with a marked flow rate in gallons-per-minute that equals or exceeds the flow rate marked on the equipment assembly.

# INTRODUCTION

Congratulations on your new purchase. **Hydro-Quip** Equipment & Control Systems are constructed of the finest materials and assembled under the strictest quality control standards. With proper care and maintenance your system will provide you with many years of reliable performance.

The following pages contain informative information concerning the operation and care of your system.

*(Note: Your Control may differ from the illustration below although the basic operation and configuration will be the same.)*

## Major Components

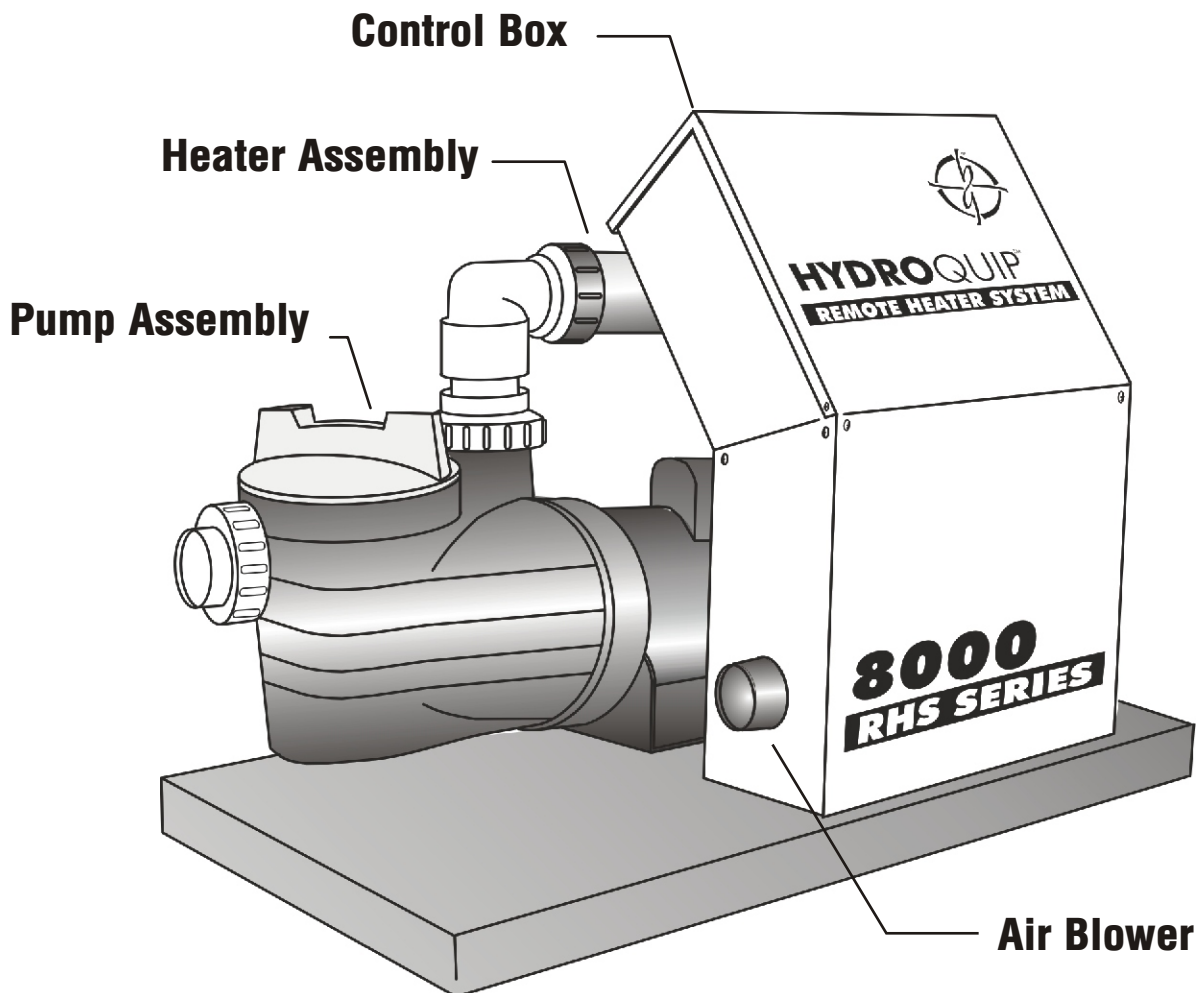

## HEATER OPERATION

*Your control system may have a convertible heater (120 volts; or 240 volts). Refer to the system data label to determine which, if any, convertible options are available to you. The heater configuration was set at the factory and may have been changed by your installer.*

A covered, 300-gallon spa will experience a heat rise approximately as detailed below.

***Your system will operate with one of the following configurations:***

**120 Volts** - The heater will operate on demand at 1500 Watts during low speed pump operation. It will automatically shut off when the high-speed pump or blower is activated. You can expect a heat rise of 1°F to 2°F per hour.

**240 Volt** - The heater will operate on demand at 5500 Watts during high and low speed pump operation. It will continue to operate when the blower is activated. You can expect a heat rise of 6°F to 8°F per hour.

# YOUR SPASIDE CONTROL

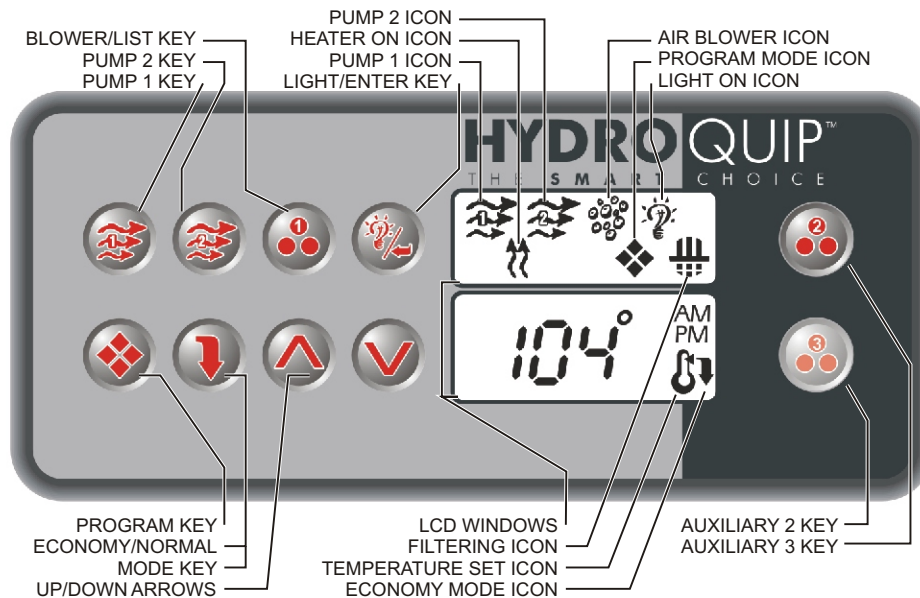

**Default System Operation:** When power is applied, or there is a temporary loss of power, the system will initiate its default programming. The filter cycle will begin 24-hours after the system has been powered up. The filtration cycle will be active for 1-hour and will repeat every 24-hours. The temperature will be maintained at 95°F.



**Pump 1 Key:** Press this key once to turn Pump 1 on. A second press will turn it off. For dual speed pump operation; Press this key once to turn Pump 1 onto Low speed, press this key a second time to turn Pump 1 onto High speed, a third press will turn the pump off. A built-in timer will shut the pump off after 20 minutes of operation unless done so manually. The Pump 1 Icon will appear on the LCD while the pump is running in High speed and flash while it is in Low speed. If the filter icon appears, a filtration cycle has begun and you will not be able to turn the pump off.



**Pump 2 Key:** Press this key once to turn Pump 2 on. A second press will turn it off. For dual speed pump operation; Press this key once to turn Pump 2 onto Low speed, press this key a second time to turn Pump 2 onto High speed, a third press will turn the pump off. A built-in timer will shut the pump off after 20 minutes of operation unless done so manually. The Pump 2 Icon will appear while the pump is running in High speed and flash while it is in Low speed.

## SPASIDE CONTROL - Continued



**Blower Key:** Press this key to turn the Blower on and off. If equipped with a multiple speed blower; press this key once to turn Blower onto High speed, a second press will turn the Blower onto Medium speed, a third press will turn the Blower onto Low speed and a fourth press will turn the Blower off. A built-in timer will shut the blower off after 20 minutes of operation unless done so manually. The Blower Icon will appear while the blower is running in High speed and flash while it is in Medium and Low speeds.



**Light/Enter Key:** Press this key to turn the light onto its highest intensity, a second press will turn the light onto medium, a third press will turn the light onto low and a fourth press will turn it off. If equipped with Fiber Optic: Press this key once to show "L1". Use the Up arrow key to turn the light onto High, Medium, Low and Off. Press the light key a second time, "F1" will appear. Use the Up arrow key to turn the Fiber Optic wheel and light on, Fiber Optic wheel off with light on and both Off. The light will automatically shut off after 2 hours. The Light Icon will appear while the light is on.



**Temperature Set Keys:** Press the Up Arrow key to increase the desired temperature. Press the Down Arrow key to decrease the temperature. The temperature can be adjusted in 1°F increments from 59°F to 104°F (5°C to 40°C). The new setting will remain on the display for 5 seconds as a confirmation. During this time the Set Point icon will be appear to let you know this is the desired and not the actual temperature. After 5 seconds the display will return to the current temperature reading. When the temperature drops to 1°F below the set temperature, the heater will be turned on until the temperature is 1°F above the set temperature. The heater icon will appear while the heater is on and flash when there is a call for heat and the heater has not yet been activated.



**Programming Parameters:** There are 11 parameters that may be programmed. Follow these procedures to set each parameter: Press and hold the Program Key for 5-seconds, the program icon (◆) will appear. You may continue to press the Program key to access the desired parameter to be modified. Once you have reached the parameter to be modified, press the Enter (Light) key. Use the Up & Down Arrow keys to adjust the value. If no key has been pressed for 15-seconds the programming mode is exited. During programming all keys other than the Program, Enter (Light) and Up & Down Arrow keys will be ignored.



**Programming Parameters:** There are 11 parameters that may be programmed. Follow these procedures to set each parameter: Press and hold the Program Key for 5-seconds, the program icon (❖) will appear. You may continue to press the Program key to access the desired parameter to be modified. Once you have reached the parameter to be modified, press the Enter (Light) key. Use the Warmer/Cooler keys to adjust the value. If no key has been pressed for 15-seconds the programming mode is exited. During programming all keys other than the Program, Enter (Light) and Warmer/Cooler keys will be ignored.

**Time of Day:** This is the first parameter and will appear with the hour flashing. To adjust, press the Enter (Light) key. Use the Warmer/Cooler keys to adjust the hour from 00: to 11:. Press the Program key, then Enter (Light) key to adjust minutes, use the Warmer/Cooler keys to adjust the minutes from :00 to :59. Press the Program key to confirm the new setting and move to the next parameter to be programmed.

**Filtration Start Time 1: ("Fon1")** appears in the display. To adjust, press the Enter (Light) key. Use the Warmer/Cooler keys to adjust the hour from 00 to 11. Press the Program key, then Enter (Light) key to adjust minutes, use the Warmer/Cooler keys to adjust the minutes from 00 to 59. Press the Program key to confirm the new setting and move to the next parameter to be programmed.

**Filtration Duration 1: ("Fdu1")** appears in the display. To adjust, press the Enter (Light) key. Use the Warmer/Cooler keys to adjust from OFF (always off) to 12 (always on). Press the Program key to confirm the new setting. The display will then return to the next parameter to be programmed.

**Filtration Start Time 2: ("Fon2")** appears in the display. To adjust, press the Enter (Light) key. Use the Warmer/Cooler keys to adjust the hour from 00: to 11:. Press the Program key, then Enter (Light) key to adjust minutes, use the Warmer/Cooler keys to adjust the minutes from :00 to :59. Press the Program key to confirm the new setting and move to the next parameter to be programmed.

**Filtration Duration 2: ("Fdu2")** appears in the display. To adjust, press the Enter (Light) key. Use the Warmer/Cooler keys to adjust from OFF (always off) to 12 (always on). Press the Program key to confirm the new setting. The display will then return to the next parameter to be programmed.

**Economy Start Time 1: ("Eon1")** appears in the display. To adjust, press the Enter (Light) key. Use the Warmer/Cooler keys to adjust any hour from 00 to 23. Press the Program key, then Enter (Light) key to adjust minutes, use the Warmer/Cooler keys to adjust the minutes from 00 to 59. Press the Program key to confirm the new setting and move to the next parameter to be programmed.

**Economy Duration 1: ("Edu1")** appears in the display. To adjust, press the Enter (Light) key. Use the Warmer/Cooler keys to adjust from OFF (always off) to 24 (always on). Press the Program key to confirm the new setting. The display will then return to the next parameter to be programmed.

**Economy Start Time 2: ("Eon2")** appears in the display. To adjust, press the Enter (Light) key. Use the Warmer/Cooler keys to adjust any hour from 00 to 23. Press the Program key, then Enter (Light) key to adjust minutes, use the Warmer/Cooler keys to adjust the minutes from 00 to 59. Press the Program key to confirm the new setting and move to the next parameter to be programmed.

**Economy Duration 2: ("Edu2")** appears in the display. To adjust, press the Enter (Light) key. Use the Warmer/Cooler keys to adjust from OFF (always off) to 24 (always on). Press the Program key to confirm the new setting. The display will then return to the next parameter to be programmed.

**Economy Start Time 3: ("Eon3")** appears in the display. To adjust, press the Enter (Light) key. Use the Warmer/Cooler keys to adjust any hour from 00 to 23. Press the Program key, then Enter (Light) key to adjust minutes, use the Warmer/Cooler keys to adjust the minutes from 00 to 59. Press the Program key to confirm the new setting and move to the next parameter to be programmed.

**Economy Duration 3: ("Edu3")** appears in the display. To adjust, press the Enter (Light) key. Use the Warmer/Cooler keys to adjust from OFF (always off) to 24 (always on). Press the Program key to confirm the new setting and exit to the Time/Temperature display.

## SPASIDE CONTROL - Continued



**Economy Mode:** Press this key to toggle between Economy and Normal operation. The Normal Mode will automatically maintain the water temperature at the desired set point. If the set point has not been programmed, the temperature will remain at 95°F. The **Economy Mode** will maintain the water temperature at 20°F below the set point until manually removed from this mode. When the Economy Mode is used the factory programming is overridden until midnight of the current day. When the Economy Mode is active, the Economy icon will appear solid in the display window.

### OPTIONAL



**Auxiliary 2 Key:** If equipped, press this key to turn Pump 3 on. A second press will turn Pump 3 off. A built-in timer will shut the pump off after 20 minutes of operation unless done so manually.



**Auxiliary 3 Key:** If equipped, press this key to turn on Fiber Optic lighting and color wheel. A second press will turn the color wheel off while the light is still activated. A third press will turn both the light and color wheel off. Fiber Optic lighting will automatically shut off after 2 hours. The Light Icon will appear while the fiber optics are activated.

## ADDITIONAL FEATURES

**Inverted Display:** The lower display can be inverted for easy viewing inside or outside the spa. Press and hold the Economy key for 2 seconds to toggle between inverted and normal display modes.

**Panel Lock:** It is possible to lock all of the spaside control keys. Press and hold the Pump 1 key for 5 seconds, “**LocF**” will appear indicating all the keys have been locked. To unlock keys, simply press and hold the Pump 1 key for 5 seconds until “**Uloc**” will appear indicating the spaside has returned to normal operation.

## ADDITIONAL FEATURES - Continued

**Smart Winter Mode:** *If the system detects ambient conditions below a preset factory setting, the system will automatically activate the Smart Winter Mode for a period of **24 hours**. In this mode, if a pump has not been powered in the last 2 hours, the system will turn it on for one minute to prevent freezing. The Filter Mode light indicator will flash while the pump is running in this mode. **Note: If you notice the pump coming on every 2 hours. This is the most likely cause. This will continue for a 24-hour period. This is normal and is the Systems protection against freezing.***

**Freeze Mode:** *If the actual spa water temperature drops below a preset factory setting, the pump and heater will be turned on until the spa water has been sufficiently heated to prevent freezing. All functions (except the alarms) will be disabled while the freeze protection is active.*

**Over Temperature Protection:** *If the water temperature exceeds 112F at the Temperature sensor 3 flashing dots will appear below the temperature display and the heater as well as all other outputs will shut off. After the water has cooled down power to the spa must be cycled off then on to reset the system. If the spa water temperature does not seem to be elevated, the error indication may have been caused by poor water flow or electrical line interference (thunder storms, voltage surges, etc.). Simply reset and monitor the system.*

**Dry Run Protection:** *If the Dry Run feature has been activated on your system, when 3 flashing dots appear in the spaside control display (see error identification) indicating that, although the pump has been activated, there is no water flowing through the plumbing for more than 10-minutes, the circulation pump will be turned off to prevent the pump from being damaged. If any key is pressed on the spaside control, the pump will restart for another 10-minutes until the problem is corrected.*

**Summer Mode:** *If activated, the Summer Mode has been created to prevent stagnant water trapped in the heater in hot climates from causing a over/high temperature (see error identification) problem. To prevent this, when the external SWM sensor is exposed to temperatures above 110°F, Pump 1 will be activated for 5-minutes every 15-minutes.*

**Power-Up Detection:** *Upon first powering the system or if a power outage occurs, the display will flash until a key is pressed. This feature also lets the user know there has been a power failure.*

## SPA LIGHT

Your control may contain a high intensity, low voltage light to enhance nighttime use.

This illustration shows how and where to find the bulb for replacement. It also shows the mounted spa light with a replacement (colored) lens. Colored lenses will further the enhancement of the light. Simply snap on or off to change the mood of your spa.

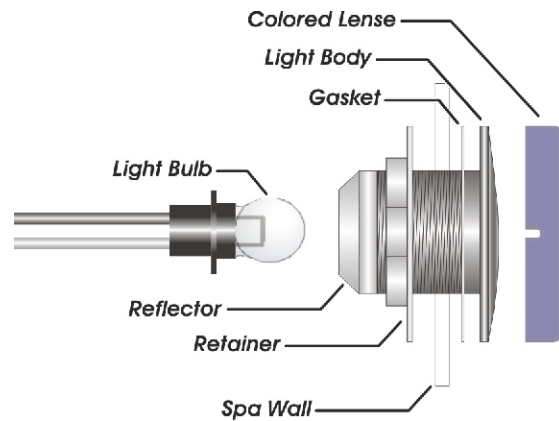

## ERROR IDENTIFICATION



*If 3 flashing dots appear below the temperature display an error and a need for service has occurred.*

**(Contact Your Local Dealer for Service)**



*If the actual spa water temperature greatly differs from the displayed temperature or the display reads a constant 33°F, a temperature sensor error and a need for service has occurred.*

**(Contact Your Local Dealer for Service)**



*If 3 flashing below the temperature display and the temperature displayed is 115°F or higher, and over temperature condition and a need for service has occurred.*

**(Contact Your Local Dealer for Service)**

**NOTE:** *If you notice the pump coming on for seemingly no reason throughout the day, the system may be in "Smart Winter Mode". If you cannot control some functions of the spa be sure to check to see if the Filtration indicator is illuminated. The spa may be in the midst of a filtration cycle. Freeze Protection and Over temperature condition will also limit or disable spa functions.*

# OPERATIONAL CONSIDERATIONS

*The following describes situations you may encounter and situations to be aware of.*

## WARM WEATHER CONDITIONS

Since your spa will normally be expected to maintain warm to hot water to be ready for your use, a great deal of attention has been directed to the **energy conservation** detail of insulation so as to keep electrical costs down. This **energy conservation efficiency** may be achieved by extensive insulation of the skirt, plumbing and spa shell, and in some climates full foam insulation may have been provided.

This **energy conservation** feature may cause an inconvenience during warmer times of the year. During warm periods of the year, the temperature within the equipment compartment can elevate to a point that the pump will automatically turn off for a short period of time (15-30 minutes) to allow the pump to cool down before automatically restarting. This cool down feature will not harm your spa but serves only to protect the pump from damage and as an indicator that it is too hot. To minimize this occurrence, refrain from using your Hydrotherapy Jets for prolonged periods of time during warm seasons.

The jet pump chosen for your spa has been specifically sized for *maximum performance* and your Hydrotherapy enjoyment.

## CHEMICAL WATER TREATMENT

Your dealer is familiar with local water conditions and which chemicals are compatible with the water and are designed specifically for your spa. This is the best person to advise you on proper water quality management.

The one thing you can do to insure years of trouble free equipment operation is to maintain proper water chemistry.

Two basic goals of the chemical water treatment are sanitizing and balancing the water.

Sanitizing simply means keeping the water free from living microorganisms including algae, bacteria and viruses. The current most popular chemicals for sanitizing include chlorine, bromine and ozone.

Balancing water means establishing a balance among pH, total alkalinity and total hardness. Water that is unbalanced can corrode the spa and it's support equipment or leave deposits of minerals. Properly balanced water is essential to allow the sanitizing chemical to work effectively. There are numerous chemical additives to help you in controlling pH, total hardness and total alkalinity. **NEVER** use softened water when filling your spa. Softened water is extremely corrosive to the metal parts of the spa equipment and may lead to an unforeseen failure.

Sometimes, despite your most diligent efforts, your water may become too far out of balance to be managed chemically. At this point it is probably better to drain and clean the spa and start over with fresh water.

Equipment failure caused by improper water chemistry will not be covered under warranty.

## **FILTRATION**

Please refer to your Spa Manufacturer's owner's manual regarding the operation, maintenance and cleaning of your filtration system.

Dirty or clogged filters can cause flow restrictions and you may experience difficulty in reaching and/or maintaining desired heat levels.

## **FREEZE PROTECTION & WINTERIZING**

When freezing weather and/or power losses are expected, contact your local spa dealer for freeze protection or winterizing recommendations for both the spa and the equipment system. Freeze related damage is not covered by the Hydro-Quip warranty.

# TROUBLESHOOTING

*The following describes situations and possible solutions to common problems you may encounter as a spa owner.*

## NOTHING OPERATES

**Main Breaker is OFF** - *Set to On.*  
**Sub-Panel Breaker Off** - *Set to On.*  
**Equipment GFCI Off** - *Set to On.*  
**Power switch in Off position** - *Set to On.*  
**Components not plugged in** - *Plug in components.*  
**Power cord not plugged in** - *Plug in power cord.*  
**Over or High Temperature Protection On** - *Refer to Section 3*

## NO, LOW OR SURGING WATER FLOW

**Air Lock in Plumbing System** - *“Bleed” the system.*  
**Restricted Flow** - *Insure that the water shut-off valves are open and that suction fittings are not blocked by debris.*  
**Dirty Filter** - *Clean or replace filter.*  
**Low Water Level** - *Increase water level to recommended level.*

## NO LOW SPEED PUMP OPERATION

**Low Level Programming Incorrect** - *Contact your local dealer.*  
**Over or High Temperature Protection On** - *Press button to reset.*  
**Pump Not Plugged-In** - *Plug in the Pump.*

## NO JETS OR BLOWER OPERATION

**Blower or Pump Not Plugged-In** - *Plug in the Blower or Pump.*  
**Over or High Temperature Protection On** - *Press button to reset.*

## NO THERAPY JET OPERATION

**Water Shut-Off Valves are Closed** - *Open Shut-Off valves.*  
**Dirty Filter** - *Clean or replace filter.*  
**Jets Not Properly Adjusted** - *Adjust Jets properly.*  
**Diverter Valve Not Properly Adjusted** - *Adjust diverter valve properly.*  
**Thermal Overload Tripping** - *Check for restricted flow of water.*  
**Over or High Temperature Protection On** - *Press button to reset.*

## WATER LEAKS

**Spa Overfilled** - *Adjust water level.*

**Too Many People in the Spa** - *Adjust water level.*

**Drain-Valve Left Open** - *Close drain valve.*

**Couplings or Unions Loose** - *Tighten or contact your local dealer.*

**Pump Seal Leaking** - *Contact your local dealer.*

**Plumbing / Connections Leaking** - *Contact your local dealer.*

**Water Leaking from Spaside Control** - *Contact your local dealer.*

**Water in Air Blower Plumbing** - *Contact your local dealer.*

## NO HEAT

**Temperature Not Set Correctly** - *Adjust Set Point.*

**Over or High Temperature Protection On** - *Press button to reset.*

**Current Limiting On** - *120V Systems will not heat if High Speed or Blower is on.  
Contact your local dealer.*

**No Power** - *Reset breaker at service panel.*

**Low Water Flow** - *Clean or Replace filter.*

## HIGH HEAT

**Temperature Sensor Not in Dry-Well** - *Place sensor in dry-well.*

**Temperature Set Too High** - *Adjust Set Point.*

**High Ambient Temperature** - *Remove spa cover.*

## GFCI BREAKER TRIPS OCCASIONALLY

**Lightning or Electrical Storm, Power Surge, Extremely Humid Conditions, or Radio Frequency Interference** - *Reset GFCI Breaker.*

*NOTE: The GFCI breaker must be properly installed by a licensed electrician.*

## GFCI BREAKER TRIPS IMMEDIATELY

**Defective Component or Improper GFCI Breaker Installation** - *Contact a qualified service technician or the factory for assistance.*

## NO LIGHT OPERATION

**Light Bulb Defective** - *Replace bulb or contact your local dealer.*

**Reflector has Fallen Off** - *Replace deflector or contact your local dealer.*

**Light Not Plugged-In** - *Plug in the Light.*



# SYSTEM DATA LABEL

The system data label is located on the control box. This label is very important and contains information you will need to establish your electrical service. The voltage and amperage ratings are shown on the bottom of the label. Product, Model, Serial and Code numbers are also shown on the label.

**Note:** This information will be necessary if you should ever have to request warranty or any other type of service.



**HYDROQUIP**<sup>TM</sup>  
THE **SMART** CHOICE<sup>TM</sup>

**ORDER CODE:** \_\_\_\_\_

**MODEL:** \_\_\_\_\_

**SERIAL:** \_\_\_\_\_

**CODE:** \_\_\_\_\_

**VOLTS:** \_\_\_\_\_

**AMPS:** \_\_\_\_\_

**PRODUCT:** \_\_\_\_\_

**REFER TO NEC FOR  
BREAKER SIZING**

# NOTES

*Use this section to jot down any information you may need at a later date.*

**Dealer:** \_\_\_\_\_ **Date of Install:** \_\_\_\_\_

**Contact:** \_\_\_\_\_ **Phone:** \_\_\_\_\_

**Address:** \_\_\_\_\_

**City:** \_\_\_\_\_ **State:** \_\_\_\_ **Zip:** \_\_\_\_\_

**Notes:** \_\_\_\_\_  
\_\_\_\_\_  
\_\_\_\_\_  
\_\_\_\_\_  
\_\_\_\_\_  
\_\_\_\_\_  
\_\_\_\_\_  
\_\_\_\_\_  
\_\_\_\_\_  
\_\_\_\_\_  
\_\_\_\_\_  
\_\_\_\_\_  
\_\_\_\_\_  
\_\_\_\_\_  
\_\_\_\_\_

## WARRANTY INFORMATION

To all original purchasers, **HYDRO**QUIP warrants its products to be free from defects in material and workmanship for a period of one year from the date of purchase.

**HYDRO**QUIP will repair or replace the part, which in our opinion, is defective.

This warranty excludes damage as a result of: normal wear, freezing, low voltage, chemical abuse, accident, negligence, alteration, improper installation, use or care.

To obtain warranty service, return defective products within the warranty period to **HYDRO**QUIP.

Purchaser is responsible for removal or reinstallation labor, freight charges, or any other such costs incurred in obtaining warranty service.

**HYDRO**QUIP assumes no responsibility for incidental or consequential damages. Some states do not allow the exclusion of incidental or consequential damages, so the above limitations and exclusions may not apply to you. This warranty gives you specific legal rights and you may also have other rights, which vary from state to state.

**THE SPA DEALER MAY PROVIDE A DIFFERENT WARRANTY,  
CONTACT YOUR SPA DEALER FOR DETAILS**

## WARRANTY INFORMATION

To all original purchasers, **HYDRO**QUIP warrants its products to be free from defects in material and workmanship for a period of one year from the date of purchase.

**HYDRO**QUIP will repair or replace the part, which in our opinion, is defective.

This warranty excludes damage as a result of: normal wear, freezing, low voltage, chemical abuse, accident, negligence, alteration, improper installation, use or care.

To obtain warranty service, return defective products within the warranty period to **HYDRO**QUIP.

Purchaser is responsible for removal or reinstallation labor, freight charges, or any other such costs incurred in obtaining warranty service.

**HYDRO**QUIP assumes no responsibility for incidental or consequential damages. Some states do not allow the exclusion of incidental or consequential damages, so the above limitations and exclusions may not apply to you. This warranty gives you specific legal rights and you may also have other rights, which vary from state to state.

**THE SPA DEALER MAY PROVIDE A DIFFERENT WARRANTY,  
CONTACT YOUR SPA DEALER FOR DETAILS**



**HYDROQUIP<sup>TM</sup>**

13345 Estelle Street • Corona, CA 92879-1881

Email: [hq@hydroquip.com](mailto:hq@hydroquip.com) • Internet: <http://www.hydroquip.com/>

Telephone: 909.273.7575 • Fax: 800.332.7190